

balco+tec

Innovative solutions for balconies and terraces





balco+tec

Outdoor spaces, our system:
quality that lasts over time

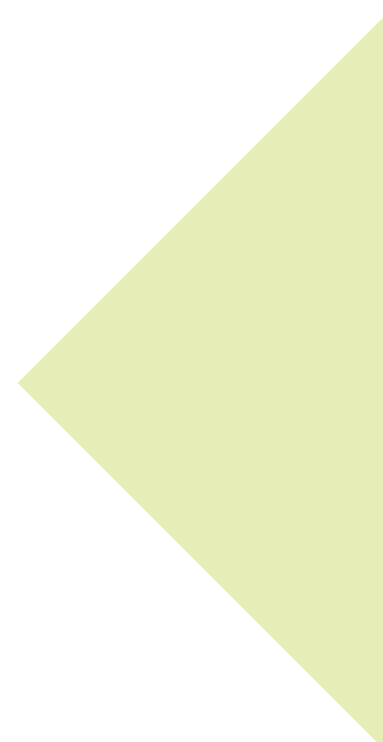

When installing floors on balconies and terraces, common occurrences are water infiltration, stagnation, cracked tile or tile edges worn down by rain and humidity.

To prevent these problems, Profilitec has developed **BALCOTEC**, a system designed to protect outdoor flooring by uncoupling the ceramic covering from terrace and balcony substrates incorporating anti-fracture, load-resistance and waterproofing functions.

Provides effective water management

Protects the edges of tiles installed at the perimeters

Waterproofs the screed

Addresses issues related to expansion and contraction

INDEX

01 THE SYSTEM p. 05

02 COMPONENTS p. 06 - 27

- **FLOORTEC** UNCOUPLING MEMBRANE _____ p. 06 - 09
- **FOILTEC/15** WATERPROOFING STRIP _____ p. 10 - 11
- **KOLLTEC** SINGLE-COMPONENT ADHESIVE _____ p. 12 - 13
- **FIXXTEC** SEALING ADHESIVE _____ p. 14 - 16
- **STC-DP** PERIMETER DRAIN _____ p. 17 - 18
- **STC-DC** VERTICAL DRAIN _____ p. 19 - 21
- **BORDERTEC** PERIMETER PROFILES _____ p. 22 - 24
- **COFLEX** EXPANSION JOINTS _____ p. 25 - 27

03 INSTALLATION STEPS p. 28 - 35

04 COMPONENTS AND TOOLS p. 36 - 37

THE SYSTEM

EN

- screed 1
- thin-set adhesive 2
- BORDERTEC 3
- KOLLTEC 4
- FOILTEC/15 5
- FLOORTEC 6
- FOILTEC/E 7
- BORDERTEC junction 8
- BORDERTEC corner 9
- COFLEX 10

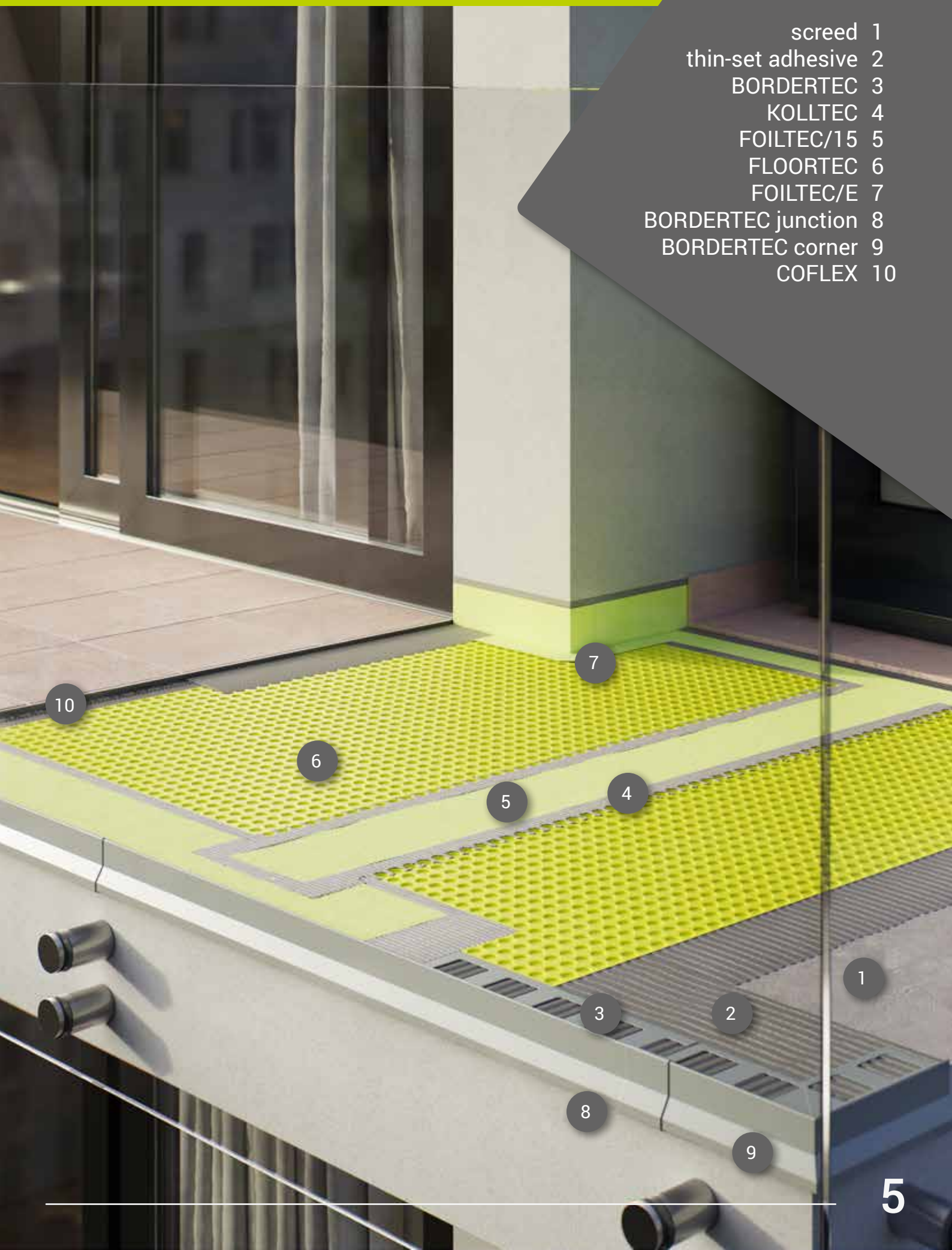

FLOORTEC

UNCOUPLING MEMBRANE



FLOORTEC

Find out more about the FLOORTEC membrane. Scan the QR code.

Product benefits

- Addresses stress build up between the substrate and the ceramic covering.
- Compensates for vapour pressure, allowing installation without waiting for the screed to fully cure.
- Waterproofs the substrate.
- When unrolled, the material is perfectly flat and has no memory*.
- Translucent to monitor thin-set coverage.

Description

FLOORTEC is the key component of the **BALCOTEK** system, ensuring **secondary waterproofing, uncoupling, vapour pressure relief** and **load resistance**.

Also ideal for indoor tile installations.

Material

The **FLOORTEC** membrane is made of high-density polyethylene, with spunbond TNT (non-woven fabric) thermally laminated on the underside. The geometric configuration of the membrane is made up of cylindrical cavities that are 3 mm in height, arranged with a constant horizontal and vertical pitch, which during installation are filled with thin-set adhesive, thus forming a solid column structure.

Technology

The (HDPE) high density polyethylene membrane has a **cylindrical cavity structure**. This also includes undercut portions for a **mechanical grip** of the thin-set adhesive once it is applied.

The geometric design of the membrane incorporates the ideal ratio of full to empty cavities which **minimizes** the **amount of thin-set adhesive needed** compared to other uncoupling systems.

The surface has been "roughened" to provide a strong bond to the thin-set adhesive as well as to allow the use of chalk-lines that will not "dust" off during tile installation. The woven fabric on the underside of the **FLOORTEC** is thermally laminated during production to prevent problems associated to the breakdown of adhesives that can dissolve when in contact with thin-set, which can be an issue with other uncoupling membranes.

The overall thickness of the membrane is 3.25 mm.

TECHNICAL CHARACTERISTICS	
Central body of the membrane	Virgin polyethylene (PE HD)
Colour of the membrane	Profilitec green
Lower body of the membrane	TNT Spunbond
Colour of the non-woven fabric layer	White
Total surface density	Approximately 700 g/m ² (+/- 50 g) - EN ISO 9864
Thickness at 2KPA	3,25 mm (+/- 1 mm) - EN ISO 9863-1
Tensile strength MD/CMD kN/m	8,8 (+/- 2 kN/m) - EN ISO 10319
Elongation with maximum load MD/CMD	33% (+/-3) - EN ISO 10319
Tensile test	0,4 N/mm ² (+0.1/-0.2) - EN 1348
Installation instructions storage	Protect from UV exposure
Format	Rolls of 1.00 m x 30.00 m
Pallet 120 x 80 cm	12 rolls (360 m ²) / pallet
Additional features	<ul style="list-style-type: none"> - Inert to water - Resistant to a wide range of chemicals - Resistant to fungi and bacteria - Resistant to root penetration - Test L-Longitudinal / T-Transversal - Test Method MD: Machine Direction / CMD (Cross Machine Direction)

Warnings

The adhesives and coating materials that are used in conjunction with the **BALCOTEC** system must be suitable for the intended use, i.e. suitable for the specific application and the type of surface on which they will be used.

It is particularly important that the coating materials are able to withstand environmental challenges. They must be able to withstand prolonged contact with water, thus protecting the structural integrity of the installation, and be resistant to frost, in order to avoid damage caused by temperature variations. When installing floors, it is essential to consider the presence of humidity contained within the

substrate, particularly if the screed is not completely cured. In these cases, it is advisable to **carefully follow the instructions** regarding **secondary waterproofing** (see dedicated paragraph on **page 31**) during the application of the **FLOORTEC** membrane. This ensures adequate protection against humidity emanating from the substrate, helping to preserve the integrity of the floor over time.

When laying **FLOORTEC** in outdoor environments, it is recommended to protect the work area from direct sunlight both during installation and in the first hours after installing the membrane. This helps to prevent the formation of adverse environmental conditions that could compromise correct drying and negatively influence the final result of the installation.

In the case of traffic areas, **protect the area** with panels or walkway protection boards.

Types of support for FLOORTEC

Before beginning the installation, make sure that the supports are:

- **flat**, so as to avoid any unevenness that could compromise the appearance and durability of the floor. Take care to correct any irregularities, using appropriate leveling products. This will ensure a uniform surface for laying **FLOORTEC** membrane, and flooring;
- **cleaned** from any residues of dust, dirt or substances that could prevent optimal adhesion of the adhesive;
- **load-bearing**.

CEMENT SCREEDS

Current regulations establish that cement screeds must undergo a **curing period** of at least **28 days** (~ one week per cm of thickness) and have a residual humidity of less than 2%, according to the volume carbide method, **before being considered ready for tile installation**. However, even after this period of time, floating screeds and heated floors may still show deformations and cracks due to mechanical stresses or temperature changes.

The use of **FLOORTEC** offers a significant advantage in this context, as it **allows the membrane to be installed directly on the concrete screed as soon as it becomes walkable**, thus not having to wait for the entire curing time.

The **FLOORTEC** membrane also offers an **uncoupling function**, effectively **compensating for tension** build up and preventing cracks and/or deformations of the screed from being transferred to the ceramic covering, especially in environments subject to high and frequent temperature changes.

The application of **FLOORTEC** therefore speeds up the flooring installation process and represents an effective solution to mitigate the problems associated with deformations and cracks of the subfloors over time, ensuring a successful installation.

PLATES AND BALCONIES

In the case of concrete slabs or balconies below grade, the **FLOORTEC** membrane, installed under the ceramic covering, can perform the additional function of a **secondary waterproofing** system.

WARNINGS FOR SECONDARY WATERPROOFING

It is important to carefully follow the specific warnings regarding waterproofing to ensure effective **protection against water infiltration and humidity** that could damage both the floor and the underlying structure over time.

Before proceeding with the installation of the **FLOORTEC** membrane, it is crucial to ensure that the support (concrete, screed) has an adequate slope to **facilitate the proper flow of water**. In the case of restoration work, if the existing floor is still sufficiently anchored and has a suitable slope, it can be retained and used as a support.

However, it is important to accurately assess the existing floor's condition and, if necessary, remove the parts that are not sufficiently adherent before installing the **FLOORTEC** membrane. Any gaps or irregularities in the slope must be restored using mortars specifically formulated for this purpose, thus ensuring a solid and uniform base for the installation of the membrane and the ceramic floor.

CERTIFICATIONS

Robinson Wheel test grade 14 (Extra-heavy commercial)	ASTM C627
Meets criteria	ANSI A118.12
Meets criteria	ANSI A118.10

FOILTEC/15

WATERPROOFING STRIP



FOILTEC/15

Learn more about the FOILTEC/15 membrane. Scan the QR code.

Product benefits

- + Waterproofs the ceramic covering support.
- + Provides vapor management.
- + Protects against mold and bacteria.

Description

The **FOILTEC/15** strip is a **waterproof membrane** in coupled polyethylene, ideal for waterproofing and protecting the floor from screed fractures and moisture migration.

Material

HDPE polyethylene, coupled on two sides with non-woven polypropylene fabric (membrane thickness 0.5 mm).

The membrane, which has **high elasticity**, compensates for small movements that may occur between the support and the covering.

Description	Waterproof membrane
Material composition	Two outer layers of non-woven polypropylene fabric with an inner waterproof layer of polyethylene
Colour	Profilitec green
Total width	150 mm
Total thickness (approx.)	0,50 mm
Material weight (approx.)	200 g /m ²
Temperature resistance (min / max)	- 30°C / + 90°C
Roll length	30 m

PHYSICAL PROPERTIES	TEST	VALUE
Burst pressure	Internal tests	≥ 2 bar
Longitudinal breaking load	DIN 527-3	270 N / 50 mm
Lateral breaking load	DIN 527-3	170 N / 50 mm
Extension longitudinal at break	DIN 527-3	60%
Lateral extension at break	DIN 527-3	70%
Longitudinal tear strength	DIN 12310-2	65 N
Lateral tear strength	DIN 12310-2	110 N
Resistance to water pressure (1.5 bar)	DIN EN 1928	≥ 1,5 bar
UV resistance	DIN EN ISO 4892-2	≥ 450 h
Vapour permeability value (SD)	DIN EN 1931	≥ 75 m
Adhesion strength	DIN EN 1348	≥ 0,5 N / mm ²
Fire classification	DIN EN 4102	B 2
	EN 13501-1	Class E

KOLLTEC

SINGLE-COMPONENT ADHESIVE



KOLLTEC

Learn more about KOLLTEC adhesive. Scan the QR code.

Product benefits

- + Single-component adhesive: lighter and less bulky to transport.
- + Fast-setting.
- + Recyclable plastic packaging.

Description

KOLLTEC is a **single-component, waterproof, fast-setting adhesive** for bonding and sealing FOILTEC waterproofing membranes, both indoor and outdoor.

KOLLTEC allows you to **seal and waterproof** the joints of the floortec uncoupling membrane, as well as the connection points with BORDERTEC profiles and SHOWERTEC drainage systems.

Material

Single-component, moisture-curing, thixotropic adhesive for installing elements in waterproofing systems.

Preparation and cleaning

The mixture is made by combining one liter of water with 3 kg of **KOLLTEC**.

Box of 6 bags – 18 kg.

The equipment must be cleaned with water if the product is wet, and mechanically if the product has already hardened.

Warnings

In hot climates, store the product packages in a cool place away from the sun.

The working times (life of the mixture) and setting times (registration time) of the adhesive vary according to ambient temperature: higher temperatures shorten them, and lower temperatures lengthen them.

IDENTIFICATION DATA	
Appearance	Powder
Colour	Light gray
Shelf life	24 months (In original packaging in a dry place. Protect from frost.)
Waterproofness under positive pressure	No penetration - EN 14891 - A7
Data collected at + 23°C temperature, 50% R.H. and no ventilation. They may vary depending on the specific conditions of the construction site.	

APPLICATION DATA	
Mixing ratio	3 kg (1 bag) – Water 1 l
Consistency of the mix	Creamy mortar
Maturation time of the mix	5 minutes
pH of the mix	13
Specific weight of the mix	1,4 kg/dm ³
Regulation time	20 minutes
Potential life of the mix	Approximately 50 minutes
Applicable thicknesses	From 1 to 5 mm
Application	Notched trowel 3x3mm (or 4x4mm)
Application temperatures allowed	From +5°C to +35°C
Waiting time for laying the covering	Immediate
Start-up	3 days
Operating temperature	From -30°C to +80°C
Product application consumption	FLOORTEC sealing with FOILTEC/15 = 325g/ml FOILTEC sealing (5cm overlap) = 70g/ml FOILTEC sealing with FOILTEC/15 = 180g/ml

FIXXTEC

SEALING ADHESIVE



FIXXTEC



Learn more about FIXXTEC adhesive. Scan the QR code.

Product benefits

- + Can be used at temperatures ranging from -30°C to $+90^{\circ}\text{C}$.
- + Can be used in outdoor and indoor environments (waterproof and UV-resistant).
- + Bonds to damp or wet surfaces.

Description

FIXXTEC is an adhesive suitable for **sealing and waterproofing** a vast number of materials (in the Profilitec product range it can be used to bond skirting boards, joints, coves, transition profiles, etc.).

This innovative product allows you to seal the junctions of **FOILTEC** membranes.

It can be used to ensure the secondary waterproofing system of the **FOILTEC** membrane by bonding it to other elements such as thresholds, balcony and terrace doors, window frames, protective sheets or **BORDERTEC** perimeter profiles and drainage systems for exteriors and interiors (e.g. bathroom, kitchen).

Material

Single-component elastic waterproof sealing adhesive based on MS polymers supplied in **packs of 12 units** in 290 ml cartridges.

It has the CE marking.

It complies with the following standards:

EN15651-1 - "Sealants for facade elements" with F EXT-INT CC performance;

EN15651-3 - "Sealants for healthcare environments" with XS3 CC performance;

EN15651-4 - "Sealants for pedestrian walkways" with PW EXT-INT CC performance.

Material properties and areas of application

FIXXTEC is resistant to UV rays and weathering and can therefore be used **both indoors and outdoors**. This adhesive is odourless, elastic, solvent-free and guarantees excellent adhesion on most materials such as aluminium, steel, wood, stone, fibre cement, concrete, glass and various plastics (after preliminary testing).

FIXXTEC can be applied both wet and underwater and can be used both as an adhesive and as a sealant-waterproofing agent.

FIXXTEC can be painted with most water- and solvent-based paints.

If particular chemical, mechanical or other stresses are expected, it is necessary to check the suitability of the material.

IDENTIFICATION DATA	
Polymerization	Hygro-hardening
Mixture consistency	Thixotropic paste
Specific weight	1,65 kg/l
Open time	About 20 minutes
Application temperatures permitted	From +5°C to +35°C
Recommended application temperatures	From +15°C to +25°C
Operating temperature	From -30°C to +90°C
Walkability	24 hours at T = +23°C
Time before use	5 days at T = +23°C
Colour	White
Storage time	12 months

PERFORMANCE	
Thickness hardening	3 mm (24 hours)
Shore A hardness	50 (DIN 53505)
Elastic modulus at 100%	≥ 1,8 N/mm ² (ISO 37 DIN 53504)
Tensile strength	≥ 2,6 N/mm ² (ISO 37 DIN 53504)
Elongation at break	2.7 (ISO 37 DIN 53504)
Moisture resistance	Excellent
Alkali resistance	Excellent
Solvent resistance	Good
Acid resistance	Low
Average cartridge yield (290 g)	10 linear meters

Warnings

Store **FIXXTEC** cartridges in cool, frost-free places, away from heat sources and direct exposure to UV rays. Opened cartridges have a limited shelf life.

The optimum operating temperature for substrate and sealant is between 15°C and 25°C.

Be careful when using alcohol or alkyd resins contained in paints as they can interfere with the hardening process of the sealant and reduce the drying time.

The hardness and thickness of the paint film can compromise the elasticity of the sealant and lead to the cracking of the painted layer.

Application method

The substrate must be sufficiently clean, solid, load-bearing and free of elements or substances that may compromise its grip.

Apply **FIXXTEC** to the substrate.

Distribute the adhesive over the entire surface, applied with a spatula.

Apply the material to be bonded as quickly as possible over the entire surface and without leaving empty spaces.

If **FIXXTEC** is used as a **joint sealant**, it must be smoothed immediately after application and any excess material immediately removed.

Average cartridge coverage 290g = 10 meters.

STC-DP

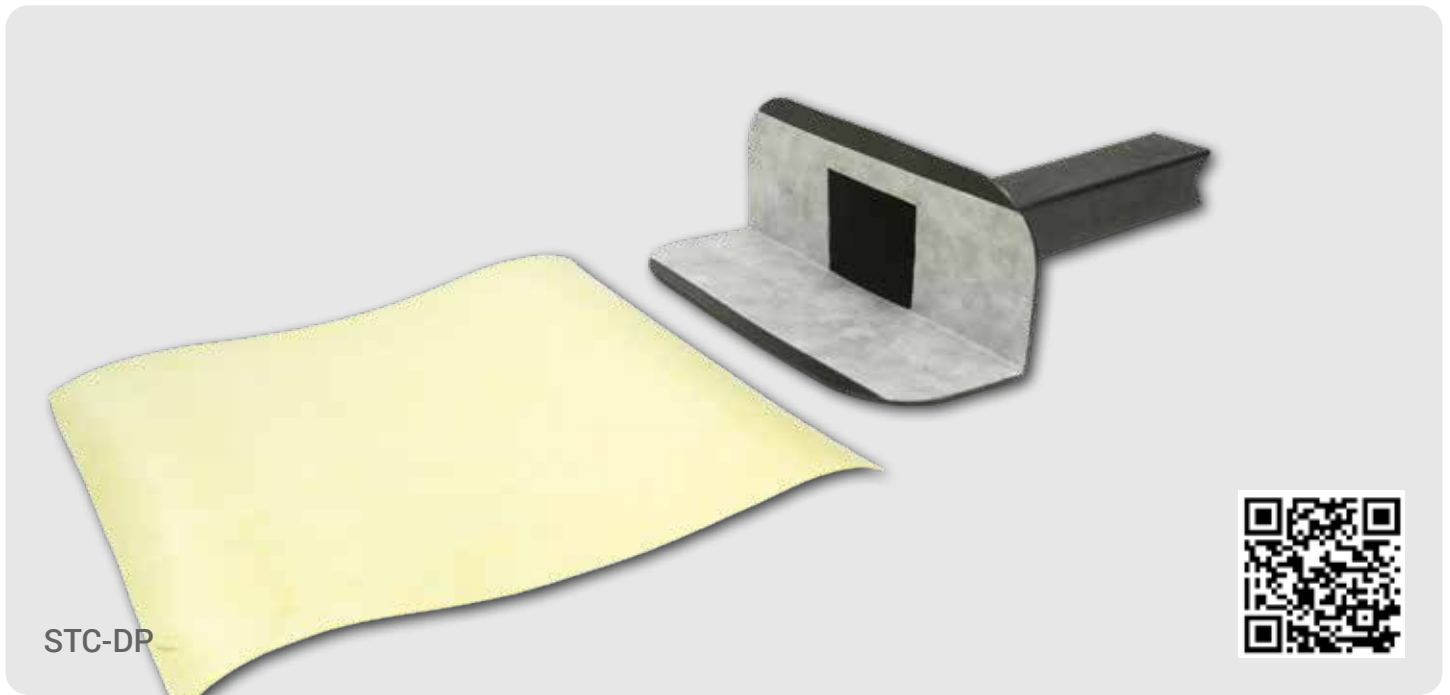

PERIMETER DRAIN



STC-DP

Learn more about the STC-DP drain. Scan the QR code.

Product benefits

-  Recyclable plastic.
-  Suitable for installation in public facilities.

Description

SHOWERTEC BALCONIES STC-DP is a sloped horizontal perimeter drain system for balconies and terraces, resistant to impact and chemicals. The system has a square-section drain pipe and a rectangular flange covered with **TNT** to adapt it to the parapet and to provide an adequate bonding surface for the **FOILTEC** waterproofing membrane.

Material

The horizontal outlet is made of **TPE** thermoplastic material and also has a TNT surface and a **FOILTEC** gusset suitable for perfectly connecting it to the secondary waterproofing system of the terrace. The package contains 2 drains and 2 gussets.

Application and function

The **SHOWERTEC STC-DP** horizontal drain system consists of a drain with a sloping horizontal rectangular-section outlet and a waterproofing gusset.

Application areas

Thanks to the size of the cross-section of their drainage channel, **SHOWERTEC BALCONIES STC-DP** drains can be used in private homes, but also in hotels or public facilities.

Application method

The subfloor must have sufficient load-bearing capacity and be sloped.

1. The **SHOWERTEC BALCONIES STC-DP** drain has a sloping rectangular-section drain pipe (48 x 57 mm) that must be inserted and bonded or mechanically fixed into an opening in the parapet.
2. Apply **FLOORTEC** to the screed, positioning it flush with the drain flange and adhesive by overlapping the appropriate pre-cut **FOILTEC** plug using **KOLLTEC**.

Dimensions

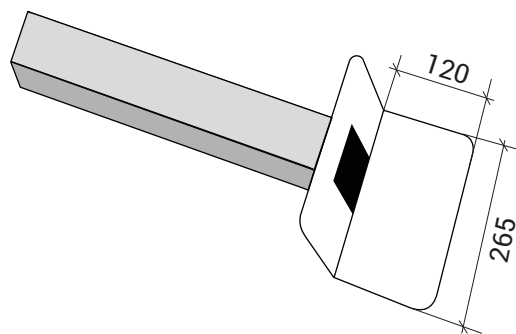
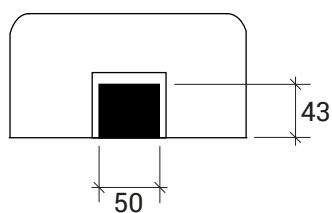
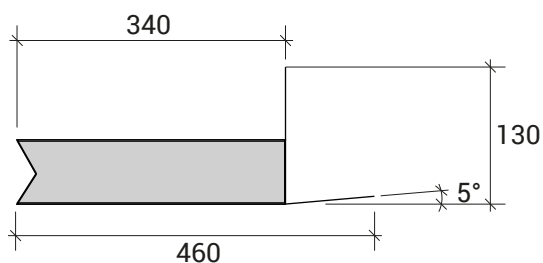

STC-DC

VERTICAL DRAIN



STC-DC

Learn more about the STC-DC drain. Scan the QR code.

Product benefits

- + Range with three drain connection diameters.
- + Sturdy steel grates in two finishes.
- + Mounting height adjustment up to 20mm tile thickness.

Description

SHOWERTEC BALCONIES STC-DC is a drain for balconies and terraces with a vertical outlet, equipped with a height-adjustable support and a sturdy stainless steel grate.

Application and function

The outdoor drain system in the **SHOWERTEC** balconies range include both a horizontal drain with slope and a vertical drain.

The latter consists of a drain with a vertical outlet, a waterproofing plug and an adjustable metal grate. The grate has a support that allows a perfect connection with the ceramic covering of varying heights. The flange of the drain system has both holes and a Velcro surface for a secure grip with **KOLLTEC** and with the pre-cut **FOILTEC** gusset, to achieve a waterproofed assembly. It can be used in private homes, hotels and public facilities, due to the presence of fixing screws for the grate and the 150mm long installation pipe.

Material

The grate support and the drain outlet are made of top quality ABS, which allows a perfect fit and millimetric adjustment of the grate positioning relative to the finished surface of the flooring. In this regard, the grate support is supplied with the practical **rigid assembly cap** so that the grate can be conveniently mounted at the end of the installation, preventing debris from entering while flooring.

The outlet is printed with a Velcro suitable for bonding with **KOLLTEC**. To complete the installation, the **FOILTEC** waterproofing membrane gusset is supplied, cut to measure for this application.

The grate is a solid and resistant block of **AISI304 stainless steel** designed without sharp edges, an exclusive Profilitec design.

Grate finishes: polished steel (IL) and brushed steel (IS)

Installation pipe length: 150mm

Fields of application

SHOWERTEC BALCONIES drains can be used in private homes, but also in hotels or public facilities, thanks to the presence of screws to prevent accidental removal of the grate.

Application method

The subfloor must have sufficient load-bearing capacity and be sloped.

1. The **SHOWERTEC BALCONIES STC-DC** vertical drain must be connected to the drain pipe of the structure.

2. After measuring the connection, if necessary, shorten the pipe by calculating the size of the hydraulic connection joint and the installation height of the floor by cutting it with a saw, ensure a straight line, with the help of a support so as not to break the drain flange (image **1.1**).

3. Make sure that the perforated flange of the drain outlet is in contact with the screed.

4. To waterproof the joint between the drain outlet and the surface of the screed previously waterproofed with the **BALCOTEC** system, the **FOILTEC** gusset supplied with the drain is required. The gusset must be set with **KOLLTEC** in a full bed, centered and overlapping the adjacent **FLOORTEC** membrane set flush with the flange.

5. The system can be combined with different types of floor coverings, such as ceramic tile, natural stone, or similar.

The grate support, with the construction cap still mounted, must be spread with ceramic adhesive all around the toothed edge and on the adjustment ring. The support has a diameter that allows a certain freedom of positioning of the ring inside the flange allowing the possibility of aligning the grate horizontally with the joints of the tile surface.

After having laid the ceramic covering around the grate support, slowly press on the construction cap until final leveling with the finished flooring.

6. Once the installation is complete and the joints are grouted, replace the construction cap with the **SHOWERTEC STC-DC** steel grate using a PH2 (cross) screwdriver and reusing the same ones for the final fixing of the grate.

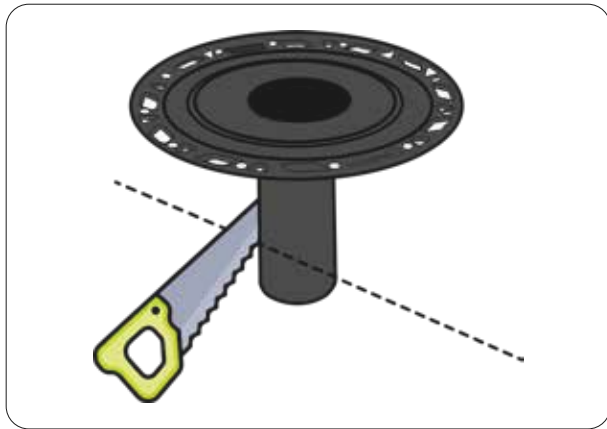

1.1

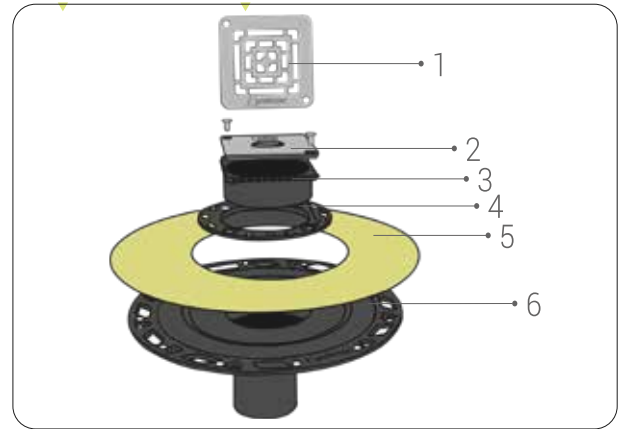

1.2

1. Grate
2. Construction cap
3. Grate support with collar
4. Adjustment ring
5. Foiltec gusset
6. Flange

Warnings and maintenance

SHOWERTEC BALCONIES STC does not require any special maintenance. It is sufficient to clean the stainless steel grate regularly using a mild detergent: this will not only keep the steel clean, but also reduce the risk of corrosion. Use only neutral detergents.

Available materials and finishes

ITEM	DRAIN DIAMETER	IS	IL
STC-DC50ABS98	DN50 (50 mm)	✓	✓
STC-DC70ABS98	DN70 (75 mm)	✓	✓
STC-DC100ABS98	DN100 (110 mm)	✓	✓

Dimensions

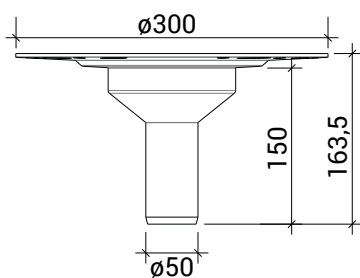

STC-DC50ABS98

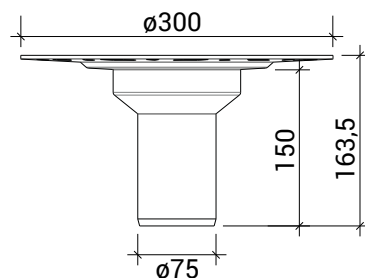

STC-DC70ABS98

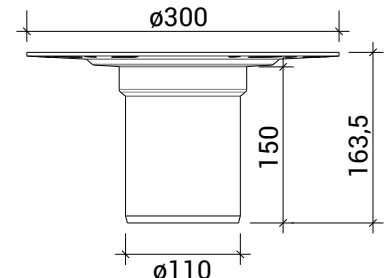

STC-DC100ABS98

BORDERTEC

PERIMETER PROFILES



BBS55A50270



Learn more about BORDERTEC. Scan the QR code.

Product benefits

- Preserves the edges of balcony and terrace tiles.
- Finishes and protects the flooring.
- Available in a wide range of colors to meet every architectural need.

Description

Perimeter profiles for finishing and protecting the exposed edges of perimeter tiles of balconies and terraces. Facilitates the flow of drainage water from the external flooring, extending the life of the supporting screed. They perform a containment function, allow improved bonding of the floor covering and act as an aesthetic solution for the perimeter covering.

Fields of application

BORDERTEC can be used in private homes and also in hotels or public facilities. The profile is equipped with a drainage angle sloped towards the outside, to protect the edge of the screed.

Material

BORDERTEC profiles are available in two different materials: powder-coated aluminum and brushed AISI304 stainless steel. They have a cut and perforated base so they can be installed with cement adhesive and with nails or screws.

how is a Profilitec code composed?

BBS55A50270 > **BBS 55 A50 270**

length
finish
size
family

Code table

BORDERTEC FAMILY	H TILE (mm)	SIZE	FINISH	MATERIAL
BBS	10	42, 55, 75, 95	IS, A11, A14, A22, A24, A25, A50, A60, A63, A64	stainless steel, aluminum
BCS	12,5	42, 55, 75, 95	IS, A11, A14, A22, A24, A25, A50, A60, A63, A64	stainless steel, aluminum
BBO	10	50	A11, A14, A22, A24, A25, A50, A60, A63, A64	aluminum
BCO	12,5	50	A11, A14, A22, A24, A25, A50, A60, A63, A64	aluminum

Available finishes



Dimensions

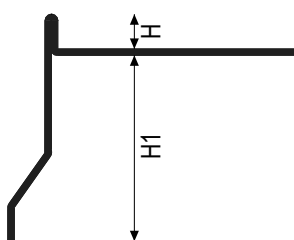

BBS

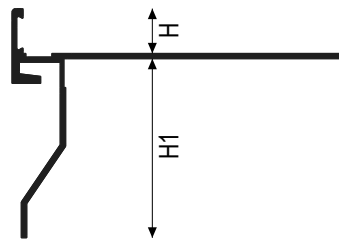

BBO

Images

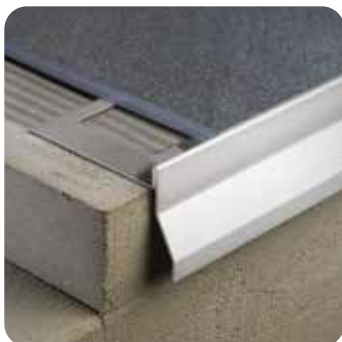

BBS - BCS

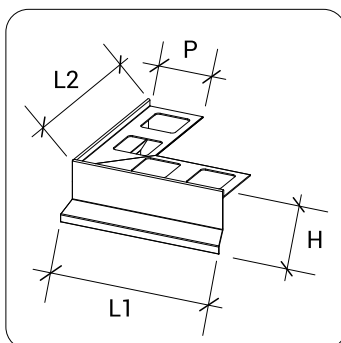

BBSE - BCSE

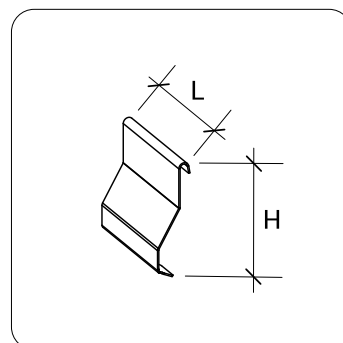

BBSG - BCSG



BBO - BCO

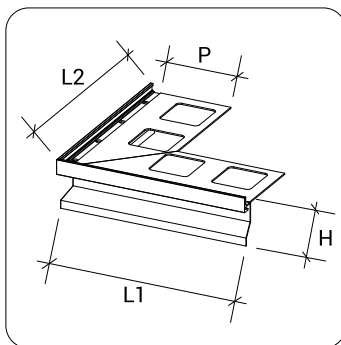

BBOE - BCOE

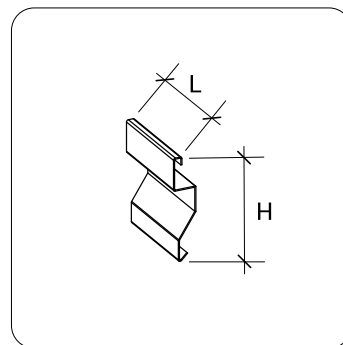

BBOG - BCOG

	BBSE	BCSE	BBOE	BCOE	BBSG	BCSG	BBOG	BCOG
H	54, 67, 87, 107	56, 69, 89, 109	62	64	56, 69, 89, 109	59, 72, 92, 112	65	68
P	92	92	102	102	/	/	/	/
L	230	230	240	240	60	60	60	60
L1=L2	230	230	240	240	/	/	/	/

Application method

The substrate must be sufficiently regular and the edge of the screed straight.

Choose the profile most suitable for the height of the tile and for the type of installation and thickness of the screed.

Position it approximately one centimeter from the front, along the edge of the surface to be tiled and install it before laying the tile and the **FLOORTEC** uncoupling membrane, complete the **secondary waterproofing**, using **KOLLTEC** to seal using the **FOILTEC** strip.

Leave a suitable space (aprox. 5 mm) between the different elements for thermal expansion, masking the joint with the joining element between the profiles themselves and between profiles and their corner accessories.

When laying the ceramic covering, leave about 5 mm to allow for **final sealing with FIXXTEC around the perimeter**.

COFLEX

EXPANSION JOINTS

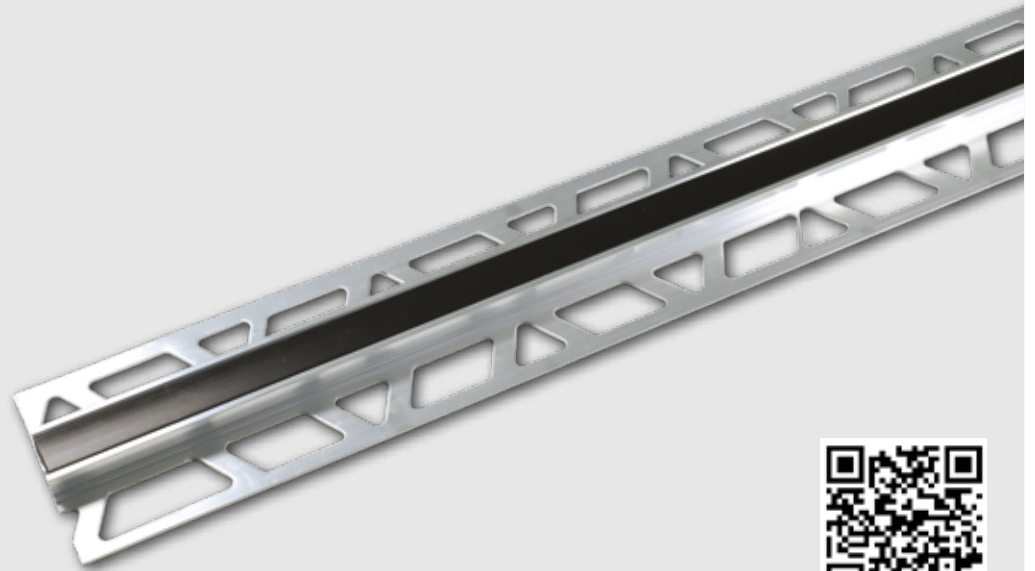

CB100AN51270



Learn more about COFLEX. Scan the QR code.

Product benefits

- + Compensates for the expansion of the ceramic covering.
- + Prefabricated profile ready for use and does not require maintenance.
- + It can be installed along the joint between the tiles without cutting them.

Description

Technical profiles that absorb thermal expansion and contraction of the flooring material, protecting against cracks and assuring a quality result. The products of the **COFLEX** family are used as fractionation joints to divide tiled areas into smaller zones.

Material

The **COFLEX** profiles made of aluminum and those made of AISI304 stainless steel incorporate compressible material made of EPDM.

The **COFLEX** profiles in synthetic material have a PVC structure co-extruded with a synthetic material of high technical characteristics in terms of elasticity, durability and resistance to the main diluted chemical agents. Available in different colors, they can find a chromatic match with the joints and with the material used for the covering. They can be used both indoors and outdoors.

Both aluminum **COFLEX** and AISI304 stainless steel **COFLEX** profiles include an expansion strip made of EPDM.

Fields of application

The range of expansion joints is wide, and understanding which profile to choose is not a complex decision. It all depends on the type of flooring (material and size, width of the joints, characteristics of the adhesives and stuccos) and the use for which it is intended. You can choose between the families of driveway joints and pedestrian joints, which differ between internal and external use.

Application method

The substrate must be sufficiently regular and the edge of the screed must be straight.

Choose a joint with a height exactly equal to the thickness of the tile.

The joint must not under any circumstances protrude from the surface of the covering but can be lower by 0,5 mm to 1 mm.

Position the joint in correspondence with the existing joint at the level of the screed (if not present, cut the screed for at least 2/3 of its thickness).

Proceed with the installation of the tiles along the flanges of the joint, placing them aligned with the profile, making sure that the latter are solidly anchored and sunk into the adhesive.

Leave a joint between the tile and the profile as wide as that between the floor tiles and then grout.

how is a Profilitec code composed?

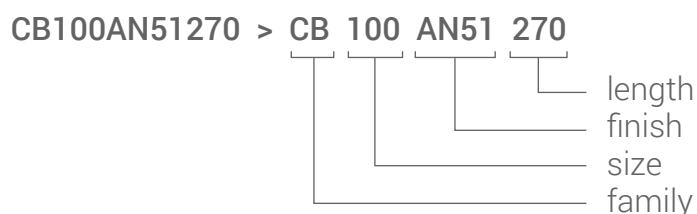

Code table

COFLEX FAMILY	H TILE (mm)	SIZE	FINISH	MATERIAL
CE	7, 9, 11, 13, 15	70, 90, 110, 130, 150	P10, P23	PVC
CA	6, 8, 10, 12,5, 20	60, 80, 100, 125, 200	P11, P23, P32, P51	PVC
CAJ	4,5, 6, 8, 10, 12,5	45, 60, 80, 100, 125	P11, P23, P32, P51	PVC
CAJP	4,5, 6, 8, 10, 12,5	45, 60, 80, 100, 125	P23	PVC
CT	8, 10, 12,5, 15, 20	80, 100, 125, 150, 200	P23, P51	inox
CTL	8, 10, 12,5, 15, 20, 25, 30	80, 100, 125, 150, 200, 250, 300	P23, P32, P51	stainless steel, aluminum, brass
CTR	3, 4,5, 6, 8, 10, 12,5, 15, 20	30, 45, 60, 80, 100, 125, 150, 200	P23, P51	stainless steel
CBR	4,5, 6, 8, 10, 12,5, 15, 20	45, 60, 80, 100, 125, 150, 200	P23, P51	aluminum
CB	8, 10, 12,5, 15, 20	80, 100, 125, 150, 200	P23, P51	aluminum, brass
CBL	8, 10, 12,5, 15, 20	80, 100, 125, 150, 200	P23, P51	aluminum, brass
CK	10, 12,5	100, 125	AN, ON	aluminum, brass
GAS	10, 12,5, 15, 20	100, 125, 150, 200	AN, AS	aluminum

Available finishes



P11 P23 P32 P51 AN AS

Dimensions

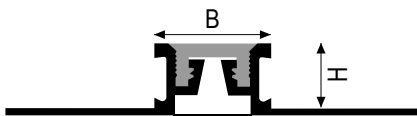

CB



1. The substrate must be cleaned of any dust, dirt or substances that could interfere with the adhesion of the adhesive and compromise the quality of the installation.

The surface must be uniform and free of significant unevenness that could affect the final appearance of the floor or compromise its stability. If necessary, it is advisable **to level the surface of the substrate** using mortars or materials suitable for this purpose, making sure to obtain a flat surface before installing **FLOORTEC**.

2. The thin-set adhesive to install the **FLOORTEC** membrane to the substrate depends on the substrate. It is crucial to select an adhesive that not only adheres firmly to the substrate, but also mechanically anchors to the **FLOORTEC** membrane fabric.

For most substrates, a good choice is to use a **thin-bed, hydraulic-setting thin-set adhesive**. This type of adhesive offers excellent adhesion and rapid setting, facilitating the installation process. It is advisable to prepare the adhesive so that it has a fluid consistency in order to allow uniform distribution and good penetration between the **FLOORTEC** membrane and the substrate.

During the adhesive preparation phase, it is essential to carefully follow the instructions provided by the manufacturer to obtain the desired consistency. It is also important to always check the compatibility between the adhesive ingredients and the materials of the substrate and the **FLOORTEC** membrane to avoid adhesion problems or deterioration over time.

3. To apply the adhesive to the substrate effectively, it is advisable to use a suitable notched trowel. We recommend a 6x6 mm toothed trowel.

Before applying the adhesive, make sure the trowel is clean and free of adhesive residue or other materials that could compromise adhesion. Make sure to apply enough adhesive to completely cover the surface and ensure good adhesion between the substrate and the **FLOORTEC** membrane, considering an average consumption of approximately 1.5 kg/m².

4. Measure and cut the **FLOORTEC** rolls to the desired length, using a utility knife or construction scissors. Make sure the cuts are clean and straight to ensure correct installation.

Once the adhesive has been applied to the substrate and is still fresh, place the **FLOORTEC** on the adhesive bed. Carefully place the membrane rolls side by side, making sure not to leave gaps or overlaps.

Immediately press the membrane using a plastic float or a weighted roller. Make sure to follow a single direction when pressing to ensure uniform and complete adhesion between the membrane and the substrate.

During application, pay attention to the open time of the adhesive, making sure to complete the installation within the time specified by the manufacturer to avoid the adhesive drying out and compromising adhesion.

It is advisable to apply the **FLOORTEC membrane well taut** already during installation, applying light traction to avoid creases or air bubbles. The particular shape and the material itself of the membrane significantly reduce the “memory” effect, i.e. the tendency of the material to curl back.

The presence of a second person can greatly facilitate the application, especially during installation and pressing of the membrane to ensure a uniform and defect-free surface.

To place a sheet next to the one previously laid without having to maintain a minimum distance between the individual sheets, make sure that the first sheet has been correctly positioned and fixed to the support using the appropriate adhesive.

Gently press the second sheet near the first, keeping them aligned and making sure that the surfaces adapt perfectly to the support without forming creases or air bubbles.

The translucency of the material allows continuous monitoring of adhesive coverage under the **FLOORTEC**.

In case **FLOORTEC** is used not only as an uncoupling membrane but also as a secondary **waterproofing** system for the screed, **it is important to carefully seal the joints, flaps, connections** and open sides using **Profilitec** components.

Carefully follow the waterproofing instructions in the product data sheet.

5. To protect the newly installed FLOORTEC membrane and prevent it from detaching from the substrate, limit traffic, or place protective sheets in areas of transit on the construction site.

If the **FLOORTEC** membrane is installed outdoors, additional measures may be necessary to protect it from adverse environmental conditions. This may include the use of materials to protect the membrane from damage caused by the exposure to the sun. During the installation of the **FLOORTEC** membrane and in the first hours after, it is important to avoid direct exposure to sunlight. Prolonged exposure to UV rays could cause damage to the membrane or compromise its performance.

During the installation of the membrane, it is crucial to protect the surface from exposure to rain as water can compromise adhesion.

Before applying the adhesive for laying ceramic tiles on the **FLOORTEC** membrane, make sure to remove any stagnant water from the cavities of the membrane.

6. After applying the **FLOORTEC** membrane, the ceramic can be laid immediately using an adhesive suitable for the type of flooring. **There is no need to wait.** The choice of notched trowel for the application of the adhesive depends on the size of the tile to ensure uniform distribution of the adhesive.

When setting tile, it is essential to respect the open time of the adhesive to ensure effective bonding. Especially in cases where the coverings are subject to particular mechanical stresses or in external applications, it is advisable to carry out a full bed installation, following the current technical regulations such as UNI 11493-1. This method ensures uniform distribution of the adhesive and better overall stability of the floor.

After applying the **FLOORTEC** membrane, it is advisable to **smooth the cylindrical cavities** of the membrane with the flat side of the trowel. The quantity of adhesive for a normal installation is approximately 1.4 – 1.8 kg/m². Immediately after, it is possible to proceed with the installation of the ceramic in a single procedure, using a bed of thin-set adhesive with proper notches. However, in particular construction site situations, it is permitted to first smooth the cavities and then proceed with the laying of the adhesive for the bedding of the covering. It is advisable to carefully remove the dust by vacuuming it or, if necessary, by applying an adhesion promoter to ensure better adhesion between the adhesive and the support. Before proceeding with the installation, it is essential to always check for any incompatibilities between the materials used, to avoid problems of adhesion or deterioration over time.

7. For expansion joints, perimeter joints, and flexible connections with fixed structures, it is essential to carefully follow the **specific instructions provided in this document**, in addition to the normal rules of good practice and current regulations.

Secondary waterproofing

To ensure correct secondary waterproofing and sealing of the **FLOORTEC** membrane joint areas, **apply the FOILTEC/15 waterproofing strips with the KOLLTEC waterproofing glue**.

The same strips must also be used to seal the connections between the floor and the covering, as well as to close the perimeter area of the membrane. Make the turn-up between the wall and the floor using the **FOILTEC/15** strip, taking care to place 5 cm on the floor and 10 cm on the wall. In the case of internal or external corners, apply the appropriate **FOILTEC/I** or **FOILTEC/E** corners with **KOLLTEC**.

The strips also allow for an easily obtained connection with **fixed structures** such as door and window frames and perimeter edges in metal, wood or plastic material. **Apply the FIXXTEC one-component sealant** first to these fixed structures, then fix the remaining part of the **FOILTEC/15** strip with **KOLLTEC** in a full bed over the **FLOORTEC** membrane.

It is important to check that the **FIXXTEC** sealant is suitable for the material of the fixed structure before proceeding with the application.

Floor Drains

SHOWERTEC BALCONIES floor drain systems have been specially designed to ensure a perfect connection with Profilitec waterproofing membranes. These systems include special pre-cut **FOILTEC** membrane gussets that allow for safe and quick connection to the **FLOORTEC** system using **KOLLTEC** adhesive.

SHOWERTEC drainage systems are ideal for installation in areas that require floor drainage, both with horizontal and vertical drain, ensuring complete waterproofing and perfect integration with the Profilitec system, ensuring a reliable and long-lasting installation.

Installation instructions

Minimum size of the ceramic covering: 5x5 cm

Minimum thickness of the ceramic covering 6 mm





1_ The support must be load-bearing, flat, clean and without roughness. Spread the cement adhesive with a 6x6 mm notched trowel.



2_ Set the border starting from the corners.



3_ Cut the **FLOORTEC** membrane before and then lay it on the previously applied adhesive.



4_ Use a plastic trowel to press the membrane adequately.

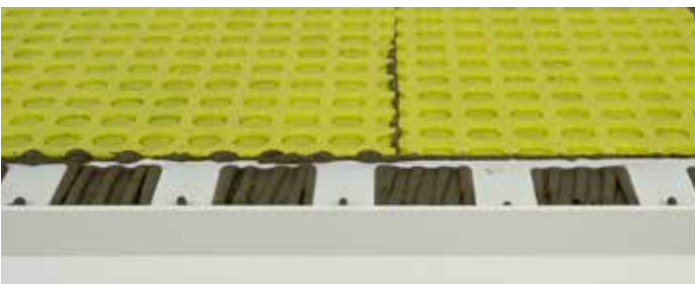

5_ In the case of multiple gussets, position the next gusset adjacent to the one already set, without overlapping them.

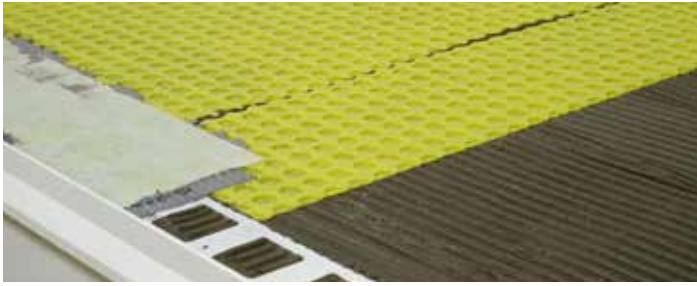

6_ When used in combination with the **BORDERTEC** perimeter profiles, place **FLOORTEC** next to the blanking of the profile and seal them by applying **KOLLTEC** adhesive over the membrane and the blanking, eventually placing the **FOILTEC** waterproofing strip on top of it all, bonding half of it to the membrane and half to the profile.

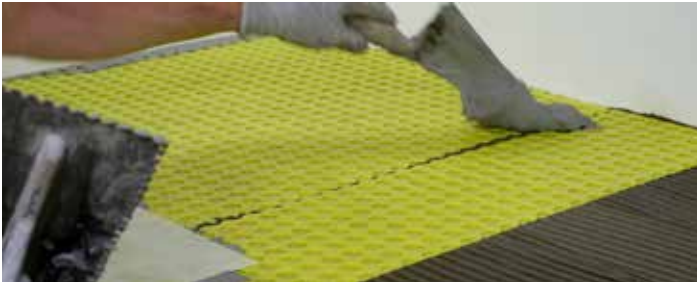

7_ Make sure to smooth the **KOLLTEC** adhesive and completely fill the cylindrical cavities of the membrane with a smooth trowel and then with a suitable notched trowel (3x3 or 4x4mm).



8_ Apply **FOILTEC/15** to seal the joints and folds; make the membrane adhere to the adhesive using a plastic trowel.

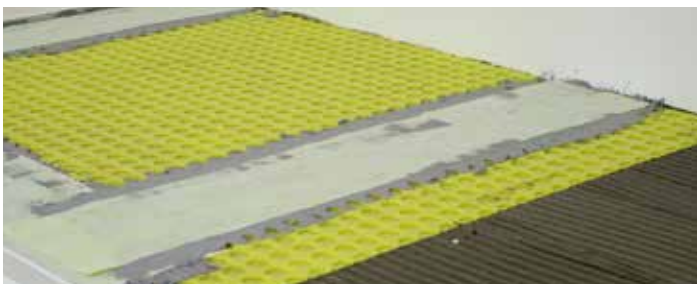

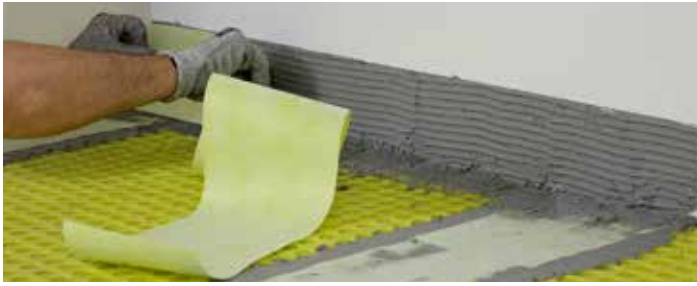

9_ In the perimeter folds the strip will extend 10cm vertically (wall edge) and 5cm horizontally (floor).

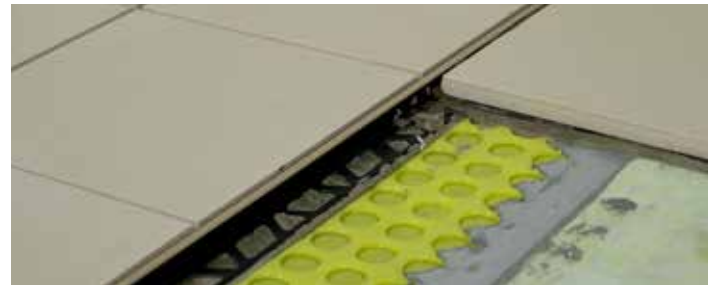

10_ Spread the cement adhesive filling the cavities of **FLOORTEC**, pressing it with the smooth trowel; then spread it with the notched trowel and set the ceramic covering and the expansion joint, where required.

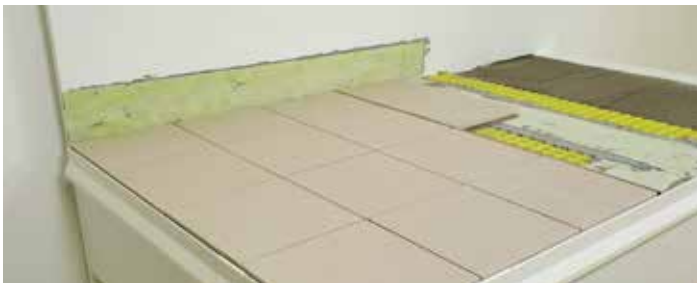

11_ The joints between the bordertec profile and the tile can be filled with the multipurpose sealant **FIXXTEC**.

COMPONENTS

Components:

▶ KOLLTEC



▶ FOILTEC/15

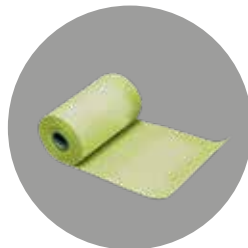

▶ BORDERTEC

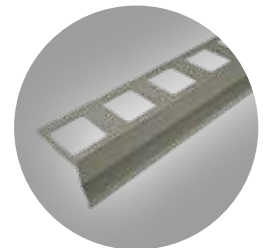

▶ FIXXTEC



▶ FLOORTEC

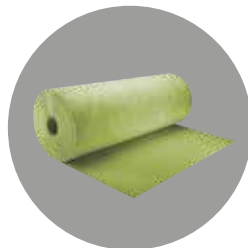

▶ COFLEX

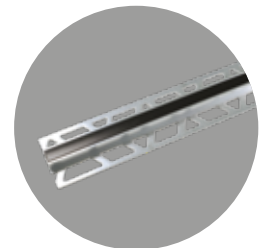

▶ FOILTEC/I

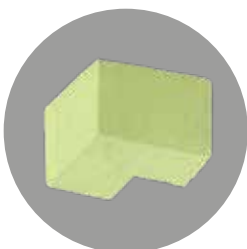

▶ FOILTEC/E

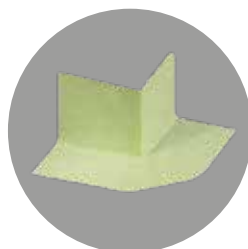

▶ STC-DC

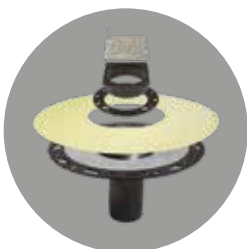

▶ STC-DP

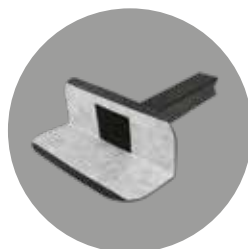

Tools (not supplied by Profilitec):

- ▶ Notched trowel (wide teeth)



- ▶ Trowel



- ▶ Notched trowel (narrow teeth)



- ▶ Level

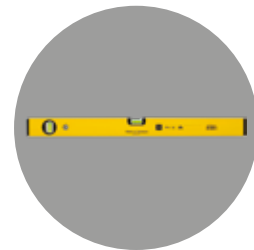

- ▶ Smooth or rubber trowel



- ▶ FIXXTEC application gun



balco+tec

Outdoor spaces, our system:
quality that lasts over time



Profilitec S.p.A.

Via Scotte, 3 - 36033 Isola Vicentina
(Vicenza), ITALY
Tel: +39 0444 268311
e-mail: profilitec@profilitec.com (ITA)

Profilitec Corp.

472 Meeting Street, Suite C, No. 301 -
Charleston, SC 29403, USA
Ph: +1 855 290 9591
e-mail: customerservice@profilitec.com

Profilitec Iberica S.L.U.

Camí de Betxí, 2 - 12540 Vila-Real
(Castellón) España
Tel: +34 964 18 29 84
e-mail: iberica@profilitec.com

www.profilitec.com



MAN_BALC_EN0624